

CADD™



Taper Delivery Mode

CADD®-Solis VIP
Ambulatory Infusion Pump
Model 2120

Patient Information Guide

smiths medical

Your Clinician's:

Name: _____

Phone Number: _____

Instructions:

Pump placement during bathing/showering: _____

Pump placement during sleep: _____

Storage of medication/fluid: _____

Notes:

Table of Contents

Introduction	4
Warnings.....	4
Cautions.....	7
CADD®-Solis VIP Pump Diagrams	9
Installing New Batteries.....	12
Using the Rechargeable Battery Pack or AC Adapter	14
Turning the Pump On and Off.....	15
Pump Screens	16
Removing a Cassette.....	19
Attaching a New Cassette	20
Priming the Tubing and Connecting to Your Catheter	22
Priming the Tubing without Changing the Cassette	24
Resetting the Reservoir Volume.....	26
Starting the Pump.....	28
Stopping the Pump.....	30
Setting a Delayed Start.....	31
Taper Down Now.....	32
Setting the Time and Date	33
What if I Drop or Hit the Pump?.....	36
Alarms and Messages.....	37
Alarm Help Screens.....	39

Introduction

Your doctor recommends the CADD[®]-Solis VIP ambulatory infusion pump as part of your treatment.

The CADD[®]-Solis VIP pump can be carried with you and is designed to deliver medication into your body. Your physician has prescribed a therapy specifically for you. Your prescription is programmed into your pump by your health care provider according to your physician's specific orders. This pump can be reprogrammed by your health care provider as your medication needs change.

Your pump is programmed for Taper delivery and is used for therapies that require a plateau rate of infusion with the option of tapering at the beginning and/or end of the infusion. There is also an option to have a KVO (keep vein open) infusion rate at the end of the infusion.

Your health care provider will instruct you on the proper use of this pump. This guide is intended to supplement those instructions. Perform only those procedures for which you have received training.

Before operating the pump, you should read the following list of warnings and cautions. It is important that you understand and follow these warnings and cautions.

Failure to properly follow warnings, cautions, and instructions could result in death, serious injury, or damage to the pump.

Warnings

- To avoid explosion hazard, do not use the pump in the presence of flammable anesthetics or explosive gases.
- If the pump is used to deliver life-sustaining medication, an additional pump must be available. Pump failure suspends medication delivery.
- Use of a syringe with the CADD[®] administration set may result in UNDERDELIVERY of medication. Syringe function can be adversely affected by variations in plunger dimension and lubricity, which can result in greater force required to move the syringe plunger. A syringe plunger loses lubrication as it ages and as a result, the amount of underdelivery increases, which could on occasion, be significant. Therefore, the type of medication and delivery accuracy required must be considered when using a syringe with the CADD[®]-Solis VIP pump.

You must regularly compare the volume remaining in the syringe to the displayed values on the pump (for example, Reservoir Vol. and Total Given) in order to determine whether underdelivery of medication is occurring. If necessary, contact your health care provider.

- Follow the instructions for use provided with the CADD[™] medication cassette reservoir, CADD[®] extension set, or CADD[®] administration set, paying particular attention to all warnings and cautions associated with their use.
- Carefully route tubing, cords, and cables to reduce the possibility of patient entanglement or strangulation. Failure to observe this warning could result in patient injury or death.
- There are potential health hazards associated with improper disposal of batteries, electronics, and contaminated (used) reservoirs and extension sets. Dispose of used batteries, reservoirs, extension sets, and other used accessories, or a pump that has reached the end of its useful life, in an environmentally safe manner, and according to any regulations that may apply.

- Common portable and mobile consumer electronic devices may cause interference with the pump. Observe the pump to verify normal operation. If abnormal performance is observed, it may be necessary to reorient or relocate the pump away from radio frequency transmitting devices.
- Residential/facility wiring must comply with all applicable electrical codes. Do not bypass power cord connections. Do not remove a prong from the power cord. Failure to comply may result in fire or electrical shock.
- When the pump is powered off, medication is not delivered, alarms are not sensed or indicated, the display is blank, the keypad does not respond to presses, and the amber and green lights are not lit.
- A rechargeable battery pack that has reached the end of its useful life must be replaced with either another CADD[®]-Solis rechargeable battery pack or with 4 AA batteries.
- Do not use rechargeable NiCd or nickel metal hydride (NiMH) batteries. Do not use carbon zinc (“heavy duty”) batteries. They do not provide sufficient power for the pump to operate properly.
- Always have new batteries available for replacement. If power is lost, nondelivery of drug occurs.
- There is no pump alarm to alert users that a battery has not been properly installed. An improperly installed battery could result in loss of power and nondelivery of drug.
- Always check the battery compartment for fluid or debris before inserting the batteries, and do not allow any fluid or debris to fall into the battery compartment. Fluid or debris in the battery compartment may damage the battery contacts and could result in loss of power and nondelivery of drug.
- If the pump is dropped or hit, the battery door may become broken or damaged. Do not use the pump if the battery door is damaged because the batteries will not be properly secured. This may result in loss of power and nondelivery of drug.

- Do not use other AC adapters with the pump. AC adapters from other companies can damage the rechargeable battery pack and the pump, and could result in loss of power and nondelivery of drug.
- Always clamp the tubing before removing the cassette from the pump. Removing the cassette without closing the clamp could potentially cause unregulated gravity infusion.
- Attach the cassette properly. A detached or improperly attached cassette could result in unregulated gravity infusion of medication from the reservoir, or a reflux of blood.
- If you are using a CADD[®] administration set or CADD[™] medication cassette reservoir that does not have the Flow Stop feature, you must use a CADD[®] extension set with anti-siphon valve or a CADD[®] administration set with either an integral or add-on anti-siphon valve to protect against unregulated gravity infusion that can result from an improperly attached cassette.
- Do not prime the fluid path with the tubing connected to your catheter as this could result in overdelivery of medication or air embolism.
- To prevent air embolism, ensure that the entire fluid path is free of all air bubbles before connecting to your catheter.
- If the pump is dropped or hit, inspect it for damage. Do not use a pump that is damaged or not functioning properly. If necessary, contact your health care provider.

Cautions

- Do not operate the pump at temperatures below 2°C (36°F) or above 40°C (104°F) to avoid damaging the electronic circuitry.
- Do not store the pump at temperatures below –20°C (–4°F) or above 60°C (140°F) to avoid damaging the electronic circuitry. Do not store the pump with a CADD™ medication cassette reservoir or CADD® administration set attached.
- Do not expose the pump to humidity levels below 20% or above 90% relative humidity to avoid damaging the electronic circuitry.
- Inspect the AA batteries for damage or wear to the metal or plastic insulation prior to use, or after the pump has been dropped or hit. Replace the batteries if any damage is noted.
- Do not store the pump for prolonged periods with the batteries installed. Battery leakage could damage the pump.
- If the power up results in an error message indicating that the protocol library was lost, do not proceed with using the pump. Contact your health care provider.
- If delivery of an infusion is affected by a time or date change, an alarm message appears and must be confirmed.
- Do not immerse the pump in cleaning fluid or water. Do not allow solution to soak into the pump, accumulate on the keypad, or enter the battery compartment, USB port, remote dose cord jack, or power jack areas. Moisture buildup inside the pump may damage the pump.
- Do not clean the pump with acetone, other plastic solvents, or abrasive cleaners, as damage to the pump may occur.
- The pump should *not* be directly irradiated by therapeutic levels of ionizing radiation due to the risk of permanent damage to the electronic circuitry. The best procedure to follow is to remove the pump during therapeutic radiation sessions or diagnostic levels of radiographic and fluoroscopic radiation. If the pump must remain in the vicinity during a diagnostic or therapy session, it should be shielded, and its ability to function properly should be confirmed following treatment.

- Do not expose the pump directly to ultrasound, as permanent damage to the electronic circuitry may occur.
- Magnetic fields produced by magnetic resonance imaging (MRI) equipment may adversely affect the operation of the pump. Remove the pump during MRI procedures and keep it at a safe distance from magnetic energy.
- Use of this pump on patients monitored by electronic equipment may cause artifactual interference. As with all electronic equipment, electrical artifacts which affect the performance of other equipment, such as ECG monitors, can occur. The user should check the correct function of the equipment prior to use.
- Do not use the pump in hyperbaric chambers as they affect how the pump works and may also cause damage to the pump.
- Use only Smiths Medical accessories that are specified for use with the CADD[®]-Solis VIP ambulatory infusion pump, as other brands may adversely affect pump operations.
- Failure to push the AC adapter connector all the way into the power jack may result in an intermittent connection and the connector may dislodge, causing a loss of power to the pump.
- If you are using a CADD[™] medication cassette reservoir in which the medication is frozen, thaw at room temperature only. Do not heat in a microwave oven as this may damage the product and cause leakage.

CADD®-Solis VIP Pump Diagrams

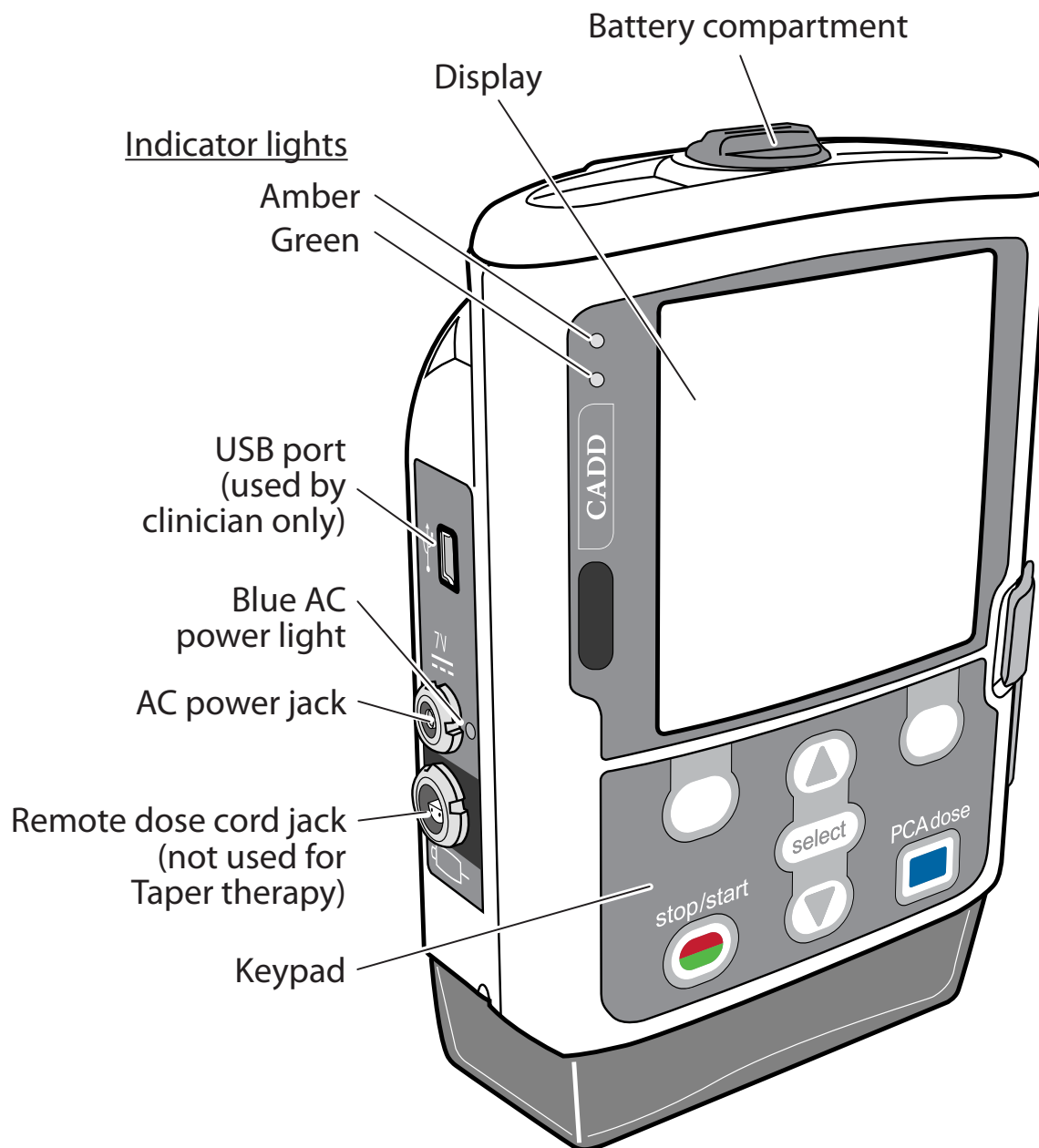

Green Light: Flashes when the pump is running and delivering medication.

Amber Light: Flashes when the pump is stopped, an alarm exists, or the battery or the reservoir volume is low. ***If the amber light is continuously lit, the pump is inoperable and you must contact your health care provider.***

Note: At times, both indicator lights may flash. This means the pump is running, but will require your attention soon (for example, for a low battery or low reservoir volume).

Display: Shows any information and messages. After a short time, the display turns itself off to save power. Press any key to turn the display back on.

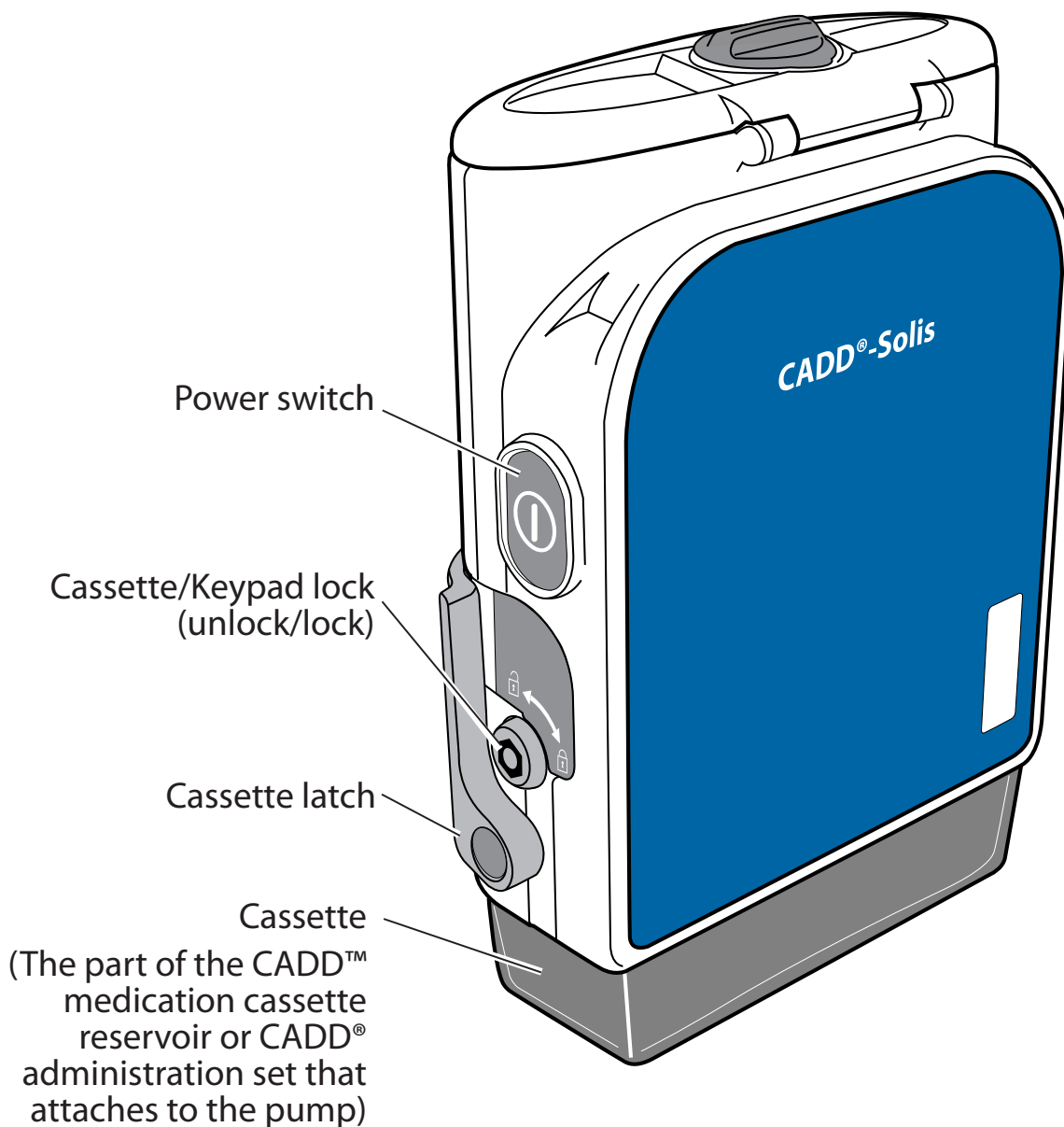

WARNING: When the pump is powered off, medication is not delivered, alarms are not sensed or indicated, the display is blank, the keypad does not respond to presses, and the amber and green lights are not lit.

Keypad

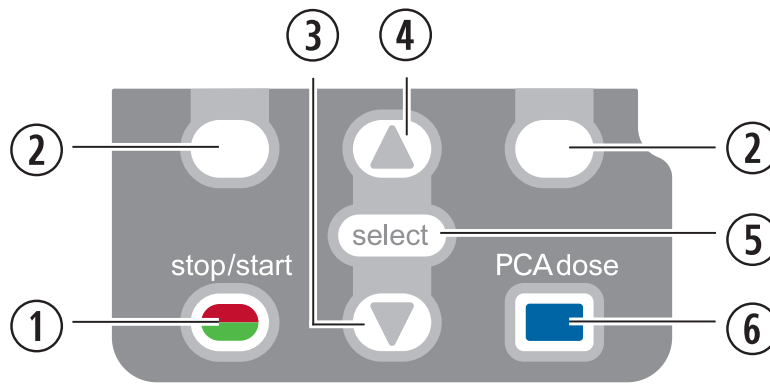

- ① Starts and stops pump delivery.
- ② “Soft keys” let you answer a question on the pump display. For example, the screen above this key may display “Yes,” in which case, pressing this key gives the question a “Yes” answer. “Soft keys” also let you move through some of the pump screens.
- ③ Lets you scroll down menus or decrease values.
- ④ Lets you scroll up menus or increase values.
- ⑤ Selects a menu item.
- ⑥ This key is not used for your therapy.

Note: The keys beep when pressed, if this feature has been turned on by your health care provider.

Installing New Batteries

Four new AA, 1.5 volt primary (non-rechargeable) alkaline batteries or the CADD[®]-Solis rechargeable battery pack must be used to power the pump. If the rechargeable battery pack is used, it can be recharged with the AC adapter.

When **Battery Low**, **Battery Depleted**, or **Rechargeable battery reached end of use** appears in the pump display, change the batteries as soon as possible. Dispose of used batteries in an environmentally safe manner and according to any regulations that may apply.

Note: Do not mix new and used batteries because it may affect low battery alarm times. Always select new batteries when replacing depleted ones.

WARNING:

- A rechargeable battery pack that has reached the end of its useful life must be replaced with either another CADD[®]-Solis rechargeable battery pack or with 4 AA batteries. Using rechargeable battery packs from other manufacturers could result in fire or explosion.
- Do not use rechargeable NiCd or nickel metal hydride (NiMH) batteries. Do not use carbon zinc ("heavy duty") batteries. They do not provide sufficient power for the pump to operate properly, which could result in death or serious injury.
- Always have new batteries available for replacement. If power is lost, nondelivery of drug occurs and depending on the type of drug being administered, could result in death or serious injury.
- There is no pump alarm to alert users that a battery has not been properly installed. An improperly installed battery could result in loss of power and nondelivery of drug and depending on the type of drug being administered, could result in death or serious injury.
- Always check the battery compartment for fluid or debris before inserting the batteries, and do not allow any fluid or debris to fall into the battery compartment. Fluid or debris in the battery compartment may damage the battery contacts and could result in

loss of power and nondelivery of drug and, depending on the type of drug being administered, could result in death or serious injury.

- If the pump is dropped or hit, the battery door may become broken or damaged. Do not use the pump if the battery door is damaged because the batteries will not be properly secured. This may result in loss of power and nondelivery of drug, and depending on the type of drug being administered, could result in death or serious injury.

To install batteries or the rechargeable battery pack:

1. Make sure the pump is stopped and powered off.
2. Using your fingers or a coin, turn the knob on the battery door counterclockwise to open the battery door.

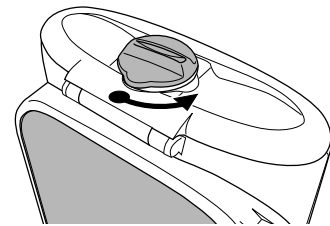

3. Hold the pump at an angle to remove the old batteries and insert 4 new AA batteries. Match the + and – markings on the batteries with the markings on the pump.

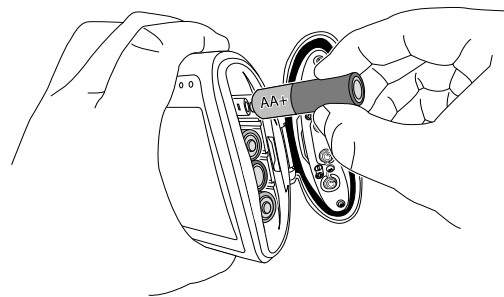

OR: If using a rechargeable battery pack, insert it as shown.

4. Close the battery door and turn the knob on the battery door clockwise to lock.

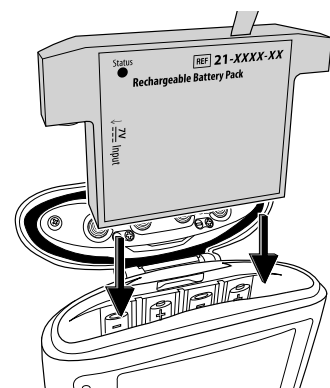

Note:

- If the batteries are installed backwards, the pump will not power on. If the pump does not power on, check the batteries, making sure to match the + and – markings on the batteries to the pump.
- Battery life may vary depending on the amount and rate of medication delivered, battery age, temperature, and active display time and backlight intensity (increasing backlight intensity shortens battery life).
- Battery power is quickly depleted at temperatures below 10°C (50°F).

Using the Rechargeable Battery Pack or AC Adapter

You may have a rechargeable battery pack and an AC adapter to power your pump. The AC adapter can be used to power the pump and/or to recharge the rechargeable battery pack. When using the AC adapter, the pump must also have 4 AA batteries or the rechargeable battery pack installed as a backup.

WARNING: Do not use other AC adapters with the pump. AC adapters from other companies can damage the rechargeable battery pack and the pump. This may result in loss of power and nondelivery of drug, and depending on the type of drug being administered, could result in death or serious injury.

Note: For complete instructions, warnings and cautions, read the *Instructions for Use* that come with the rechargeable battery pack or AC adapter.

To connect the AC Adapter:

1. Plug the AC power cord (the cord that plugs into your wall outlet) into the AC power input connector on the AC Adapter.
2. Plug the output power cord from the AC Adapter into the pump's AC power jack (labeled "7V"). Push the connector firmly into the jack until it stops. When the AC adapter is properly connected, the blue light next to the connector on the pump lights. If the pump is powered on, "**AC Adapter Connected**" appears briefly on the pump display and the battery status shows an AC power connection.

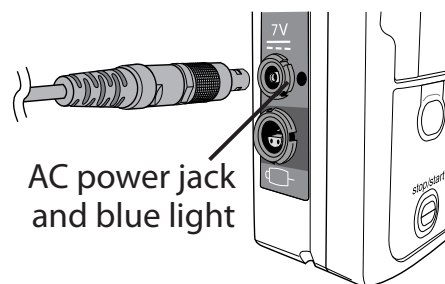
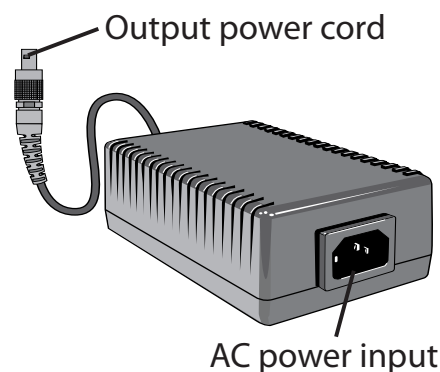

CAUTION: Failure to push the AC Adapter connector all the way into the power jack may result in an intermittent connection and the connector may dislodge, causing a loss of power to the pump.

Turning the Pump On and Off

To turn on the pump, press and hold the power switch ①.

When the pump powers on, it performs various self-tests. Watch and listen for the following:

- The green and amber lights flash.
- The display shows a blue and amber rotating arc, followed by a CADD®-Solis Ambulatory Infusion System display. If you see any stripes, or black or white pixels, or if your display appears faulty, contact your health care provider.
- When power up completes, six beeps sound. Contact your health care provider if you do not hear the beeps, because there may be a problem with the audible alarms.
- If any issues are detected during power on, alarms will sound and/or be displayed. If the alarms continue after you follow any on-screen help, contact your health care provider.

To turn off the pump, press the power switch ①. When the “Power down?” message appears, press **Yes**. The pump then powers off.

When the pump is powered off:

- The display is blank.
- Keypad presses are not detected.
- Medication is not infused.
- Alarms are not sensed, and audio and visual alarms are not displayed.
- If the AC adapter is plugged in, the blue AC power light remains on. No other lights are lit.
- If the pump is connected to AC power and a rechargeable battery pack is installed, the battery pack continues to charge.

Power Switch

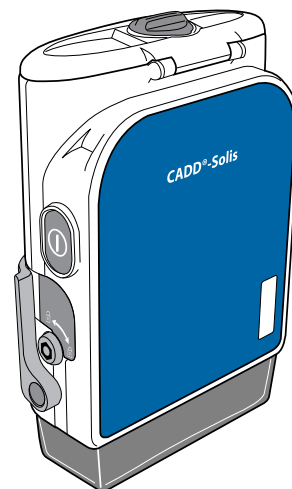

Pump Screens

Menu screen

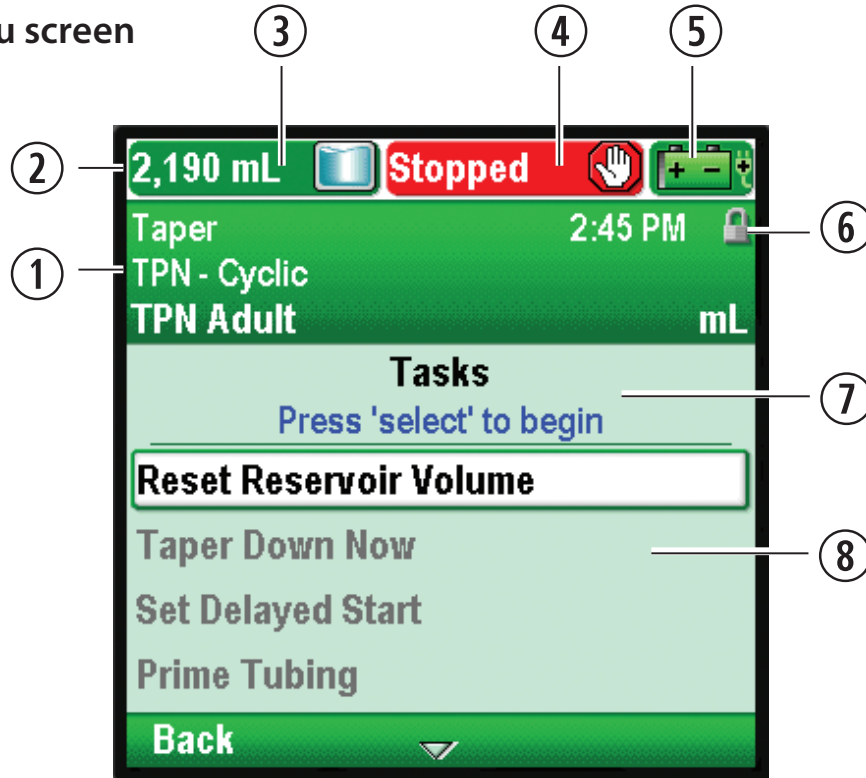

- ① Your therapy information
- ② Pump status bar. This area may show messages and alerts.
- ③ Current reservoir volume
- ④ Delivery status of the pump: Stopped or Running
- ⑤ The battery type in use, approximate amount of battery life remaining, and AC adapter in use indicator



AA batteries



AA batteries
with
AC adapter



Rechargeable
battery pack



Rechargeable
battery with
AC adapter

- ⑥ Keypad lock status: locked or unlocked
- ⑦ Screen name and help text, if any
- ⑧ Work area/contents for the displayed screen

Note: The screens shown are examples. Your pump screens may vary based on your specific therapy.

Home screen

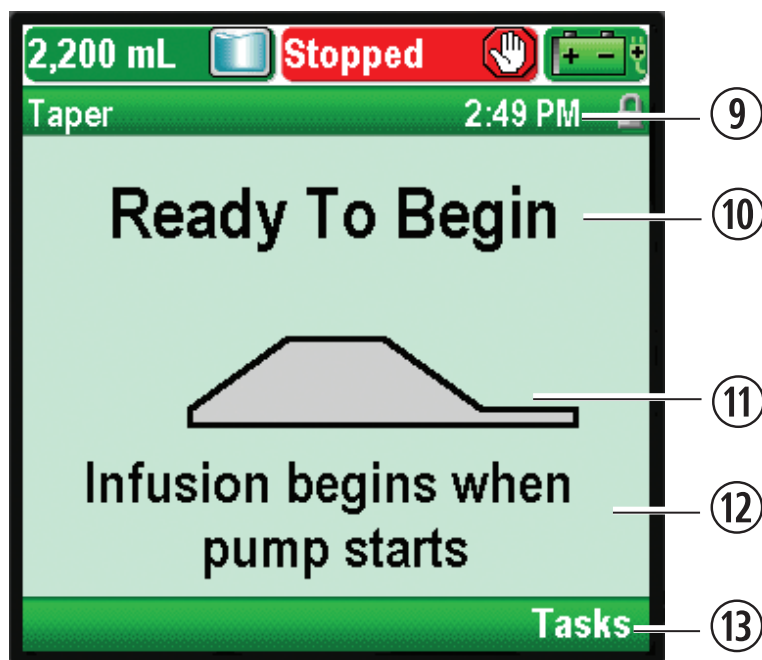

- ⑨ Current pump time
- ⑩ Current status of your infusion
- ⑪ A graphic of the infusion profile for your therapy, and the status of your infusion. The graphic uses the colors green, red, and gray. The colors indicate that the pump is running (green), or stopped (red). The graphic is entirely gray before the pump starts.
- ⑫ Information about upcoming events that are important to the pump delivery. When the pump is running, messages may indicated:
 - When the infusion will be complete
 - When a delayed start will begin
- ⑬ Options for navigating the pump. Press the “soft key” below the displayed option to select it.

Pump Status Colors

The colors green, amber, red, and blue in the pump status bar help you quickly recognize pump status. Similar to a traffic light, green means go, amber indicates caution, and red means stop:

- **Green:** Pump conditions are satisfactory.
- **Amber:** There is a condition to watch, but the current pump conditions are satisfactory.
- **Red:** There is a warning condition that requires immediate attention and infusion has stopped. All high priority and system fault alarms display in red.
- **Blue:** Low priority alarms and informational messages display in blue.

On-screen text and help in the pump display provide more information when there are conditions or alarms that need your attention. ***If you cannot correct a condition or alarm by following the on-screen help, contact your health care provider.***

For information about alarm screens, see “Alarms and Messages” on page 40.

Removing a Cassette

The medication reservoir should be changed before new infusions, and when you receive reservoir volume empty or low alarms.

Note: You should always have the supplies necessary to change your CADD™ medication cassette reservoir or CADD® administration set, as instructed by your health care provider.

WARNING: Always clamp the tubing before removing the cassette from the pump. Removing the cassette without closing the clamp could potentially cause unregulated gravity infusion, which could result in serious injury or death.

To remove a cassette:

1. Make sure the pump is stopped before removing the cassette. For instructions, see “Stopping the Pump” on page 32.
2. Close the tubing clamp.
3. If the cassette is locked, insert the pump key into the cassette/keypad lock and turn it counter-clockwise to the unlocked  position.

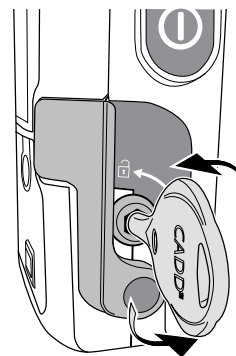

4. Push down on the cassette latch until the cassette detaches.

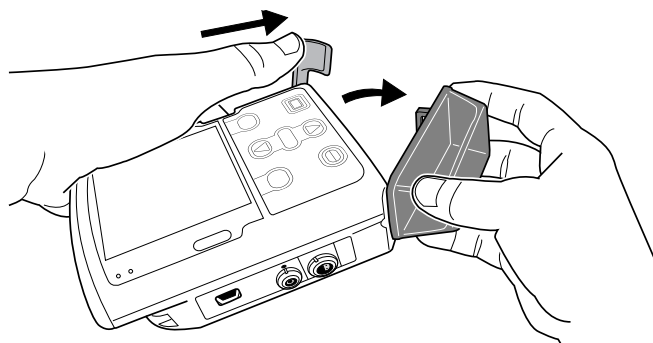

5. Remove and discard the CADD™ medication cassette reservoir or CADD® administration set as instructed by your health care provider.

Attaching a New Cassette

Obtain a new, filled CADD™ medication cassette reservoir, or CADD® administration set attached to a flexible IV bag. Refer to the *Instructions for Use* supplied with the product for information on preparing the product for use.

WARNING:

- **Attach the cassette properly. A detached or improperly attached cassette could result in unregulated gravity infusion of medication from the reservoir or a reflux of blood, which could result in death or serious injury.**
- **If you are using a CADD® administration set or CADD™ medication cassette reservoir that does not have the Flow Stop feature: you must use a CADD® extension set with anti-siphon valve or a CADD® administration set with either an integral or add-on anti-siphon valve to protect against unregulated gravity infusion that can result from an improperly attached cassette. Unregulated gravity infusion can result in death or serious injury.**

CAUTION: If you are using a CADD™ medication cassette reservoir in which the medication is frozen, thaw at room temperature only. Do not heat in a microwave oven as this may damage the product and cause leakage.

When attaching a cassette, use aseptic technique as instructed by your health care provider.

To attach a cassette:

1. Clamp the tubing on the new CADD™ medication cassette reservoir or CADD® administration set. If required, remove the blue clip from the Flow Stop feature.
2. Before attaching a new cassette, make sure the pump is powered on.

3. Make sure the cassette latch is unlocked, and open the cassette latch.

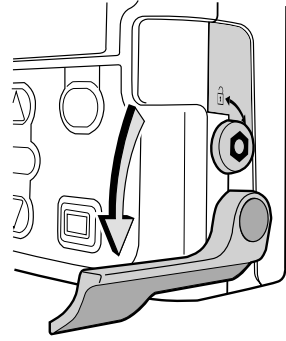

4. Insert the cassette hooks into the hinge pins on the bottom of the pump.

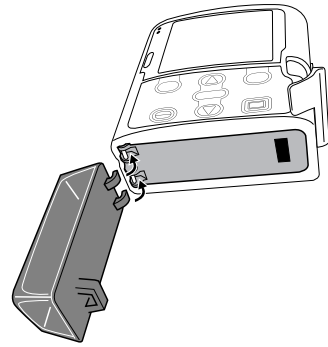

5. Push down on the cassette latch, and push up firmly on the cassette until it clicks into place.

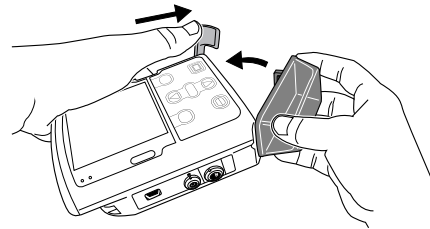

OR

Place the pump upright on a firm, flat surface, and then press down on the latch side of the pump so the cassette fits tightly against the pump.

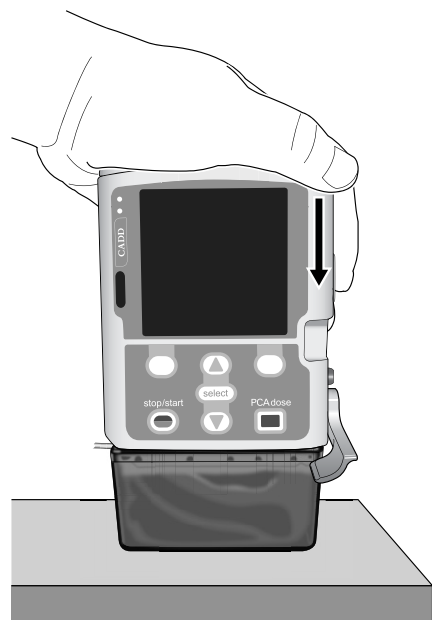

6. Lift the cassette latch into the closed position. You should be able to move the latch into the closed position with minimal to no resistance. If you experience resistance when lifting the cassette latch, DO NOT FORCE the latch. If you are unable to attach the cassette to the pump with minimal to no resistance, the cassette is not in the proper latching position. If the pump does not latch easily, unlatch the cassette and repeat the process. If unsuccessful on the second attempt, do not use the pump. Contact your care provider for further assistance.

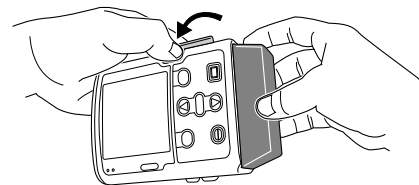

OR



7. Verify the cassette is attached correctly. Looking from left to right, the top of the cassette should line up evenly with the bottom of the pump and be securely attached. If the cassette is attached incorrectly, there will be an uneven gap between the cassette and the pump, with the gap appearing on the latch side of the pump. If an uneven gap exists, unlatch the cassette and repeat the process. If the gap exists after the second latch-up attempt, do not use the pump. Contact your care provider for further assistance.

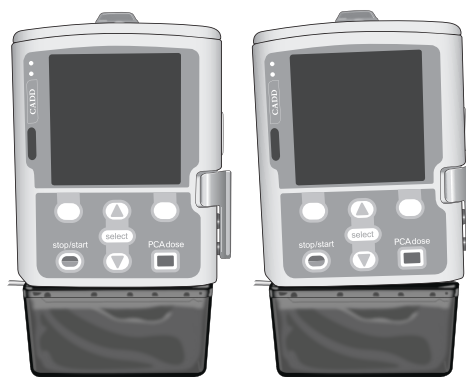

Correct

Incorrect

An uneven gap indicates that the cassette is not properly latched.

8. A message briefly appears on the pump screen so you can verify the type of cassette you have attached.
9. If required, lock the cassette by inserting the pump key into the cassette/keypad lock and turning it clockwise to the locked position. **"Cassette Locked"** appears briefly in the pump display.

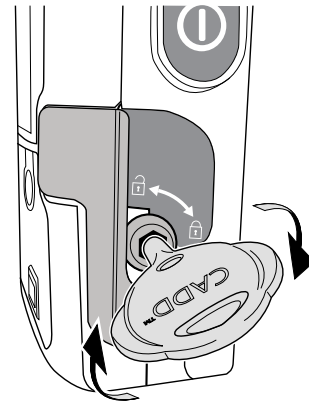

10. Once the cassette is attached, the pump automatically displays screens that allow you to prime the fluid path, reset the reservoir volume, and start the pump (see the sections that follow in this guide).

Priming the Tubing and Connecting to Your Catheter

When priming the fluid path, the tubing downstream of the pump is filled with fluid, removing any air bubbles. Prime the tubing before connecting it to your catheter.

Note: If you are not changing the cassette but wish to prime the fluid path, see “Priming the Tubing without Changing the Cassette” on page 27.

WARNING: Do not prime the fluid path with the tubing connected to your catheter as this could result in overdelivery of medication or air embolism, which could result in serious injury or death.

To prime the tubing:

1. After the cassette is attached, a **Prime tubing?** screen appears.

- If a screen like the one to the right appears, a security code is required to proceed. If you *do not* have permission to prime the tubing or if the tubing is pre-primed, select **No**. Contact your health care provider for further assistance.
- If a screen like the one to the right appears, select **Yes** to prime the tubing now, or **No** to prime later.

Prime tubing?

If tubing has been pre-primed choose 'No'. Contact health care provider if unsure.

No Yes

Prime tubing?

No Yes

2. Confirm that the tubing is disconnected from your catheter, open the clamps, and select **Prime**.

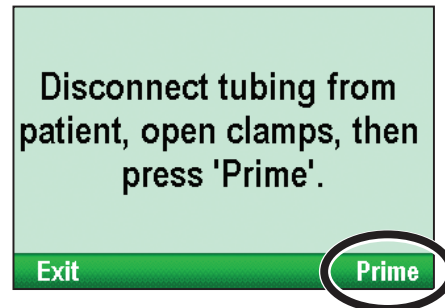

WARNING: Do not prime the fluid path with the tubing connected to your catheter as this could result in overdelivery of medication or air embolism, which could result in serious injury or death.

3. Stop priming at any time by selecting **Stop Priming**. Priming automatically stops after 10 mL are primed (or after 20 mL, if using a high volume administration set).

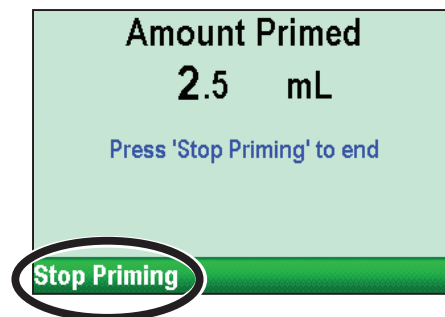

4. Continue priming as needed by selecting **Yes**, or select **No** to finish priming.

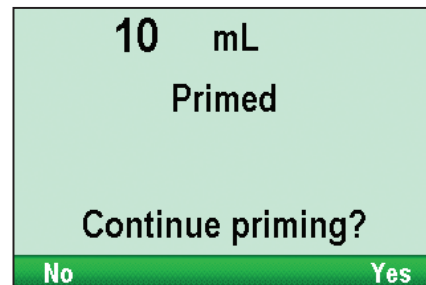



WARNING: To prevent air embolism, ensure that the entire fluid path is free of all air bubbles before connecting to your catheter. Air embolism could result in serious injury or death.

Priming the Tubing without Changing the Cassette

If necessary, or upon the advice of your health care provider, you can prime the tubing without changing the cassette.

WARNING: Do not prime the fluid path with the tubing connected to your catheter as this could result in overdelivery of medication or air embolism, which could result in serious injury or death.

To prime the tubing without changing the cassette:

1. Stop the pump if it is running.
2. In the **Tasks** menu, press  or  to highlight **Prime Tubing**, and press .

If you do not have permission to prime the tubing, a security code is required. Contact your health care provider for further assistance.

3. Confirm that the tubing is disconnected from your catheter, open the clamps, and select **Prime**.

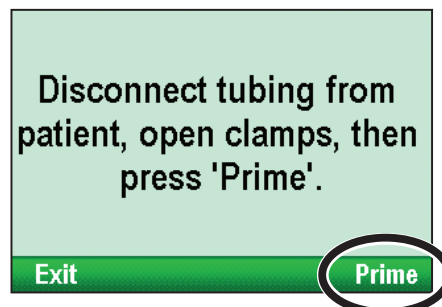
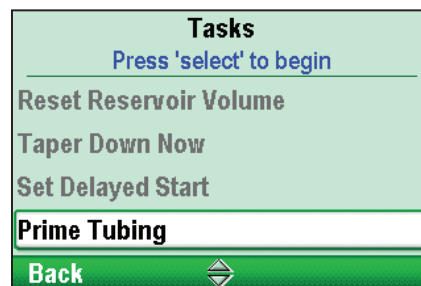

WARNING: Do not prime the fluid path with the tubing connected to your catheter as this could result in overdelivery of medication or air embolism, which could result in serious patient injury or death.

4. Stop priming at any time by selecting **Stop Priming**. Priming automatically stops after 10 mL are primed (or after 20 mL, if using a high volume administration set).

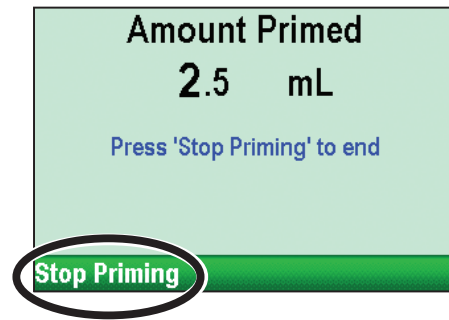

WARNING: To prevent air embolism, ensure that the entire fluid path is free of all air bubbles before connecting to your catheter. Air embolism could result in serious injury or death.

Resetting the Reservoir Volume

The reservoir volume setting indicates the amount of fluid in the reservoir. Once the reservoir volume is set, the pump keeps track of how much fluid has been delivered, and displays the remaining reservoir volume.

When a new cassette or administration set is attached to the pump, and if the pump is powered on, you may be prompted to reset the reservoir volume. However, you may also reset the reservoir volume without changing the cassette (for example, if you are using an administration set and are only changing your IV bag).

Note: Resetting the reservoir volume also resets the infusion profile. When you restart the pump, delivery starts at the beginning of the infusion period.

To reset the reservoir volume after attaching a new cassette or administration set:

1. The pump displays a question asking if you wish to reset the reservoir volume to the default amount (in this example, 2,200 mL). You will also see, “Infusion will be reset”. Select **Yes** to reset the volume and infusion profile.

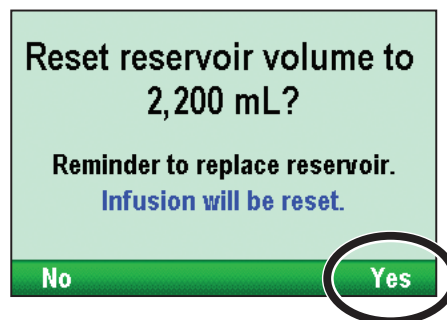

2. If you selected to reset the reservoir volume, the pump shows a **Saving...** screen.

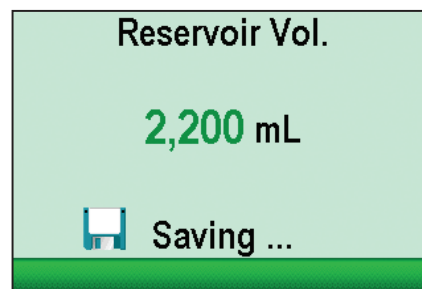

If your health care provider instructed you to change your IV bag without changing the CADD® administration set, follow the steps below.

To reset the reservoir when changing an IV bag only:

1. Stop the pump.
2. Remove the used IV bag from the administration set and attach the new IV bag to the administration set, as instructed by your health care provider.

3. In the **Tasks** menu, press  or  to highlight **Reset Reservoir Volume**, and press .

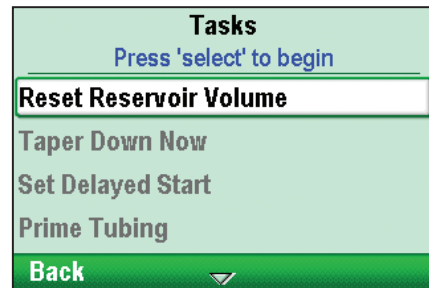

4. The pump displays a question asking if you wish to reset the reservoir volume to the default amount for your therapy (in this example, 2,200 mL). You will also see, “Infusion will be reset”. Select **Yes** to reset the volume and infusion profile.

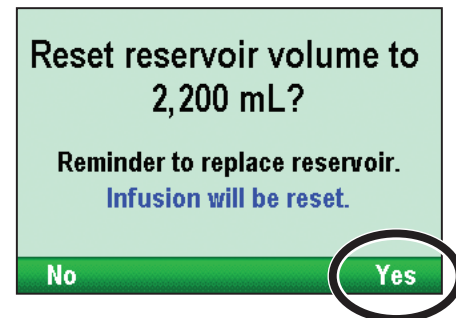

5. If you selected to reset the reservoir volume, the pump shows a **Saving...** screen.

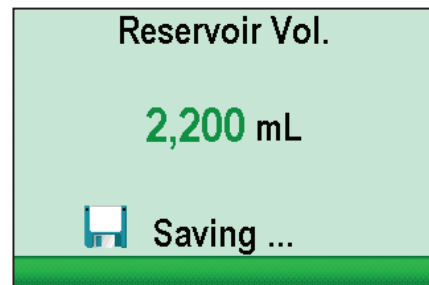

6. Press the stop/start  key to start the pump.

Starting the Pump

Infusion begins when the pump starts. When the pump is running, “**Running**” appears with green highlighting on the status bar and the green light on the pump flashes.

Note: Before starting the pump, be sure the tubing is primed and the pump is connected to your catheter as instructed by your health care provider.

To start the pump:

1. If the pump is programmed, the “**Ready to Begin**” message is displayed on the home screen.

– OR –

If the pump has been started and then stopped, the home screen uses the red color in the graphic.

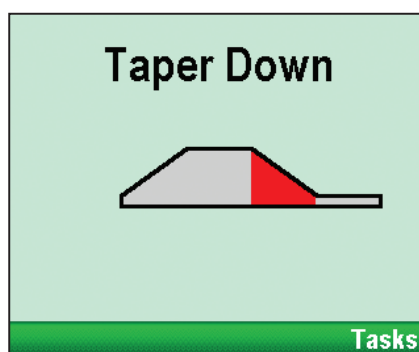
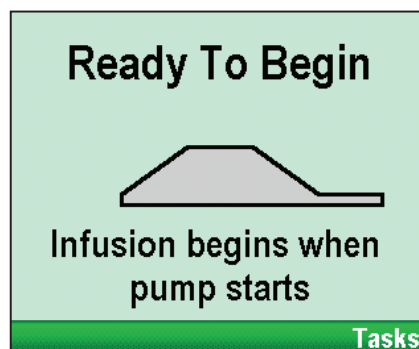

2. Press the stop/start  key on the pump.
3. If a previous infusion was stopped and the infusion was not fully delivered, a message appears: “Infusion was interrupted before completion. Finish interrupted infusion or start from beginning with new bag.” Select **New Bag** to reset the reservoir volume and reset the infusion profile, or select **Finish** to resume the infusion from the point it was when it was last running.

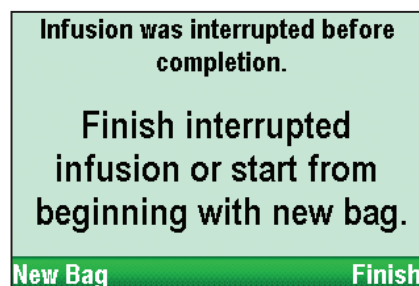

4. When **“Start Pump?”** appears, select **Yes**.

Note: If you want to set a delayed start time, see **“Alarms and Messages”** on page 40.

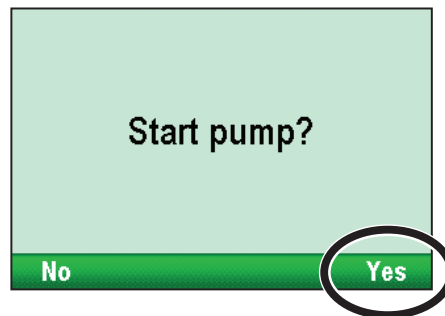

5. The pump begins running. The red **“Stopped”** message in the status bar changes to a green **“Running”** message, and **“Infusion is starting now...”** appears briefly.



If a delayed start time was set, the display turns green and a message that the infusion is delayed appears briefly on the screen, and then the **“Delayed Start”** home screen appears along with the time remaining until your infusion starts.

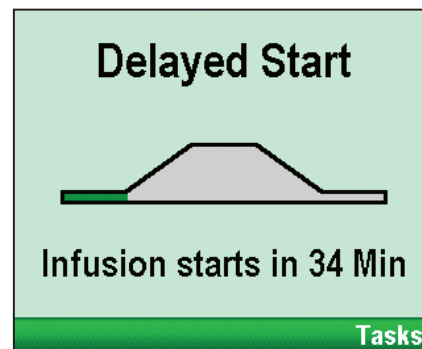

Stopping the Pump

Stopping the pump stops delivery. After the pump is stopped, **“Stopped”** appears with red highlighting on the status bar, the amber indicator light flashes, and the green indicator light is off.

To stop the pump:

1. Press the stop/start  key on the pump.

2. If your infusion is in progress, **“Taper down instead?”** appears. If you want to stop the pump immediately, select **No** to stop the pump. To taper down, select **Yes**. For more information about taper down, see page 35.

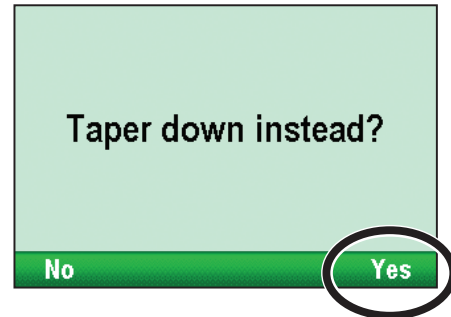

3. When **“Stop Pump?”** appears, select **Yes**.

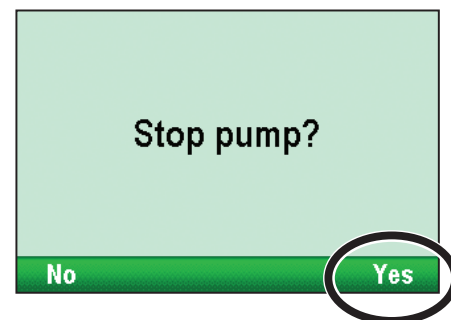

4. The pump stops running. The green **“Running”** message in the status bar changes to a red **“Stopped”** message, and **“Pump is stopping...”** appears briefly.



Setting a Delayed Start



The Set Delayed Start task allows you to delay the start of your infusion to a selected date and time. You may not set a delayed start if your infusion has already started. The pump must be running on the selected date and time for delivery to begin. When delayed start is used, the KVO (keep vein open) rate is active until the infusion begins.

To set a delayed start time:

1. In the **Tasks** menu, press  or  to highlight **Set Delayed Start**, and press .

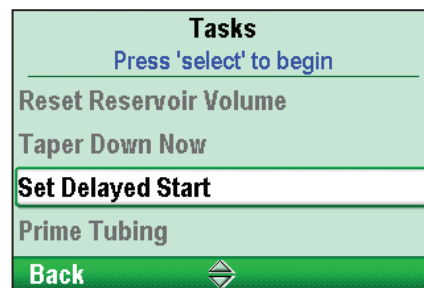
If you do not have permission to set a delayed start, a security code must be entered to unlock the keypad.



2. Press  or  until your desired start time appears on the screen, and then select **Confirm**.

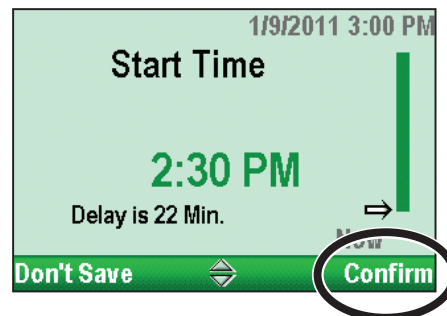

3. A confirmation message appears showing your selected start time and delay. Select **Yes** to confirm.

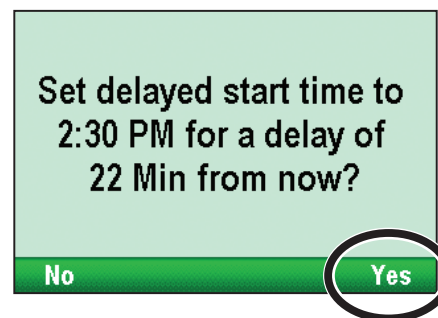

4. Press the stop/start  key to start the pump. A **"Delayed Start"** home screen shows the amount of time remaining until your infusion starts.

Taper Down Now

Taper Down Now allows you to stop your infusion early by immediately tapering down. Your taper down period is pre-programmed by your health care provider. Taper Down Now can be used only if the pump is running and delivering at the plateau rate.

To use Taper Down Now:

1. In the **Tasks** menu, press  or  to highlight **Taper Down Now**, and press .

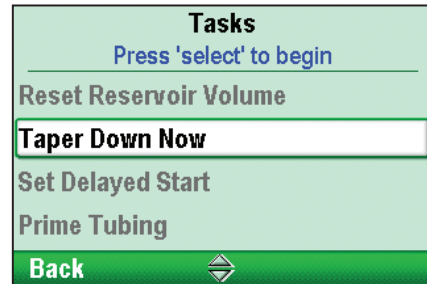

2. Select **Yes** to continue with the taper down, **No** to go back to the **Tasks** menu, or press  to edit the taper down period (if editing is allowed by your health care provider, a security code will be required).

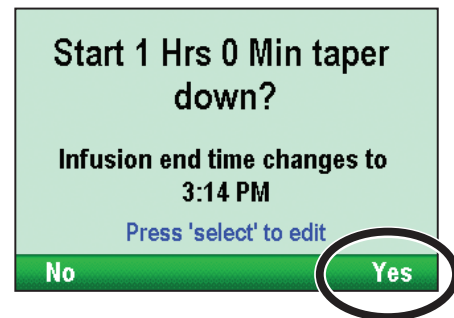

NOTE: Once you select **Yes**, you cannot restart delivery at the plateau rate without resetting the infusion period.

3. When “**Beginning Taper Down...**” appears, select **OK**.

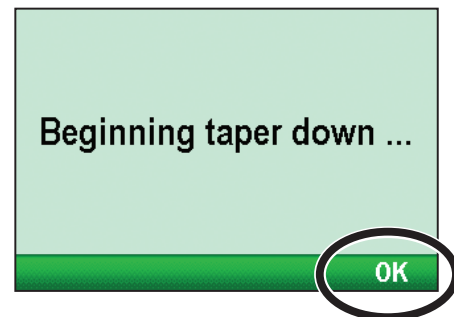









Setting the Time and Date



The time and date on the pump display should be current. The pump uses the date and time to determine when delayed starts begin. When necessary, set the time or date for the pump. The pump time does not automatically change for daylight saving time.

The pump clock is powered by a separate internal battery that recharges when the pump is powered on. The pump retains the time and date even when the AA batteries or rechargeable battery pack are removed. If the pump is off for a long period of time, the correct time and date may not be shown until the pump is powered on and the internal battery recharges; set the time and date if necessary.

To set the time:

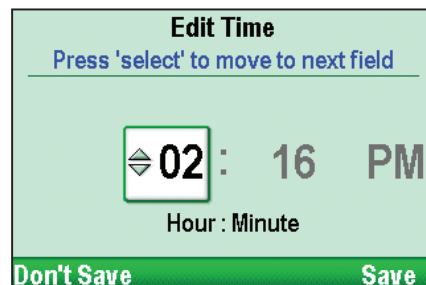
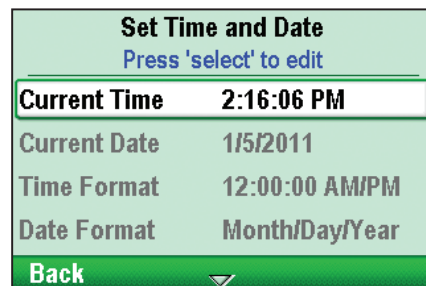
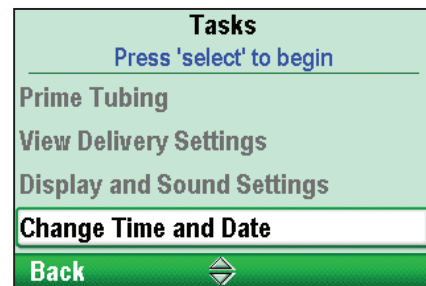
1. In the **Tasks** menu, press  or  to highlight **Change Time and Date**, and press .
2. In the **Change Time and Date** menu, press  or  to highlight **Current Time**, and press .
3. Press  or  to scroll to the correct hour (1–12, or 0–23 if your pump was set up to use a 24-hour clock) and press  to navigate to the minutes field.



4. Press  or  to scroll to the correct minutes and press  to navigate to the **AM** or **PM** field to change it, if necessary.

If your pump was set up to use a 24-hour clock, the **AM** and **PM** fields do not appear. Select **Save**.

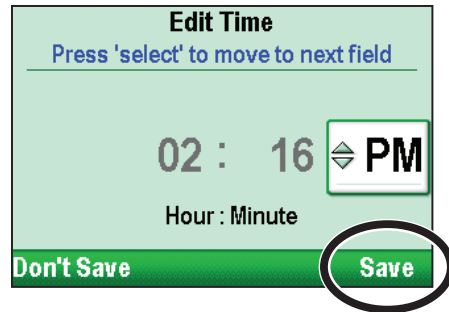
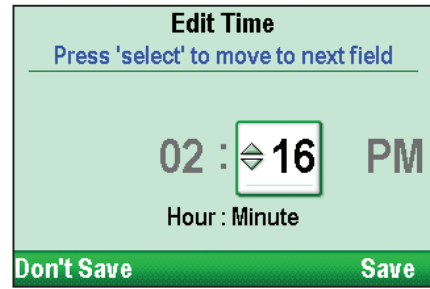

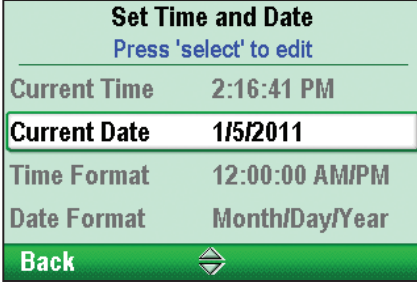

To set the date:

1. In the **Change Time and Date** menu, press  or  to highlight **Current Date**, and press .



Set Time and Date	
Press 'select' to edit	
Current Time	2:16:41 PM
Current Date	1/5/2011
Time Format	12:00:00 AM/PM
Date Format	Month/Day/Year
Back 	

2. Press  or  to scroll to the correct month and press  to navigate to the day field.

Note: This example shows the **Month/Day/Year** date format. The date format is shown below the date so that you know which field you are changing.

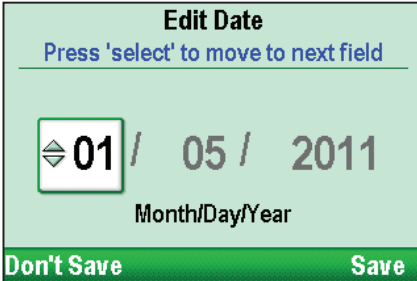

Edit Date	
Press 'select' to move to next field	
 01	/ 05 / 2011
Month/Day/Year	
Don't Save	Save

3. Press  or  to scroll to the correct day and press  to navigate to the year field.

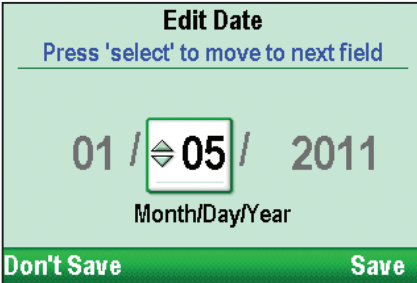

Edit Date	
Press 'select' to move to next field	
01 /  05	/ 2011
Month/Day/Year	
Don't Save	Save

4. Press  or  to scroll to the correct year and select **Save**.

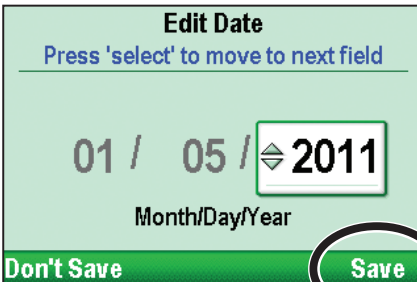

Edit Date	
Press 'select' to move to next field	
01 / 05 /  2011	
Month/Day/Year	
Don't Save	Save

What if I Drop or Hit the Pump?

What should I do if I drop the pump in water?

If you accidentally drop the pump in water, retrieve it quickly, dry the pump off with a towel, and contact your health care provider.

What if I drop the pump or hit it against a hard surface?

Immediately do the following:

- Gently twist and pull on the cassette to make sure it is still firmly attached.
- Check the battery door to make sure it is still firmly attached. If the battery door is removed, simply snap the door onto the bar that is located on the pump.

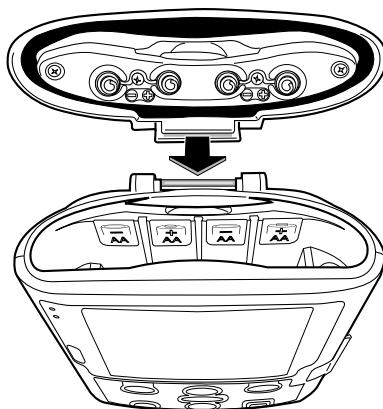

- If the pump is powered on and there are audible or visual alarms and on-screen help appears on the pump display, follow the on-screen help (see “Alarms and Messages” on page 40).

If the cassette or battery door are loose or damaged or you cannot resolve any alarms by following the on-screen help, do not use the pump. Immediately stop the pump, close your tubing clamp, and contact your health care provider.

WARNING: If the pump is dropped or hit, inspect it for damage. Do not use a pump that is damaged or not functioning properly. Depending on the type of damage, death or serious injury could result from the use of a damaged pump.

Alarms and Messages

The pump can sound multiple alarms. For many of the alarms, you have the option to “acknowledge” or “silence.”

- **Acknowledge:** Clears the alarm from the screen.
- **Silence:** The alarm stays on the screen, but is silenced for 2 minutes. The alarm continues until it is acknowledged or resolved.

The alarm and message types are as follows:

- **System Fault Alarm:** An unrecoverable error may have occurred, such as a hardware or software fault. With this alarm, the amber indicator light is continuously lit, the screen is **red**, and a two-tone alarm sounds. If a system fault alarm occurs, contact your health care provider.
- **High Priority Alarm:** This alarm always pauses or stops the pump. This alarm is accompanied by a red screen and persists until acknowledged by a key press or until the condition that triggered the alarm goes away. If silenced, the alarm sounds again after 2 minutes if the alarm condition still exists.
- **Medium Priority Alarm:** This alarm does not stop the pump (delivery continues). This alarm is accompanied by an **amber** screen and persists until acknowledged by a key press or until the condition that triggered the alarm goes away. If silenced, the alarm sounds again after 2 minutes if the alarm condition still exists.



System fault alarm (red)
with error code

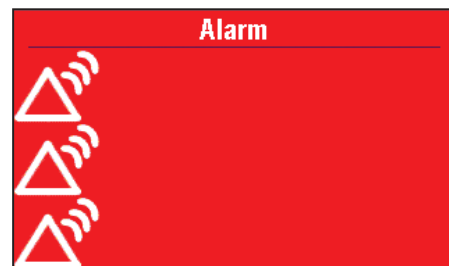

High priority alarm (red)

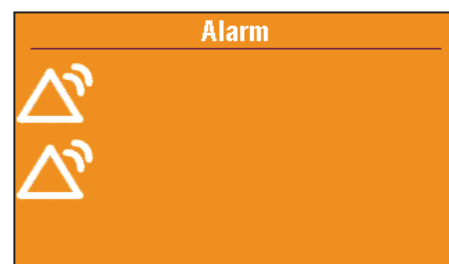

Medium priority alarm (amber)

- **Low Priority Alarm:** This alarm does not stop the pump (delivery continues). The alarm is accompanied by a **blue** screen and persists for 5 seconds (or more with some alarms) unless it is acknowledged by a key press or until the condition that triggered the alarm goes away.

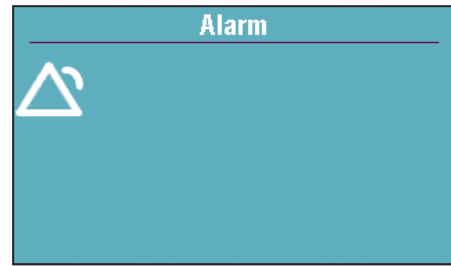

Low priority alarm (blue)

- **Informational priority message:** These messages do not stop the pump. They appear in the status bar for 5 seconds, are almost always silent, and require no acknowledgement. Examples include “Cassette Locked” and “Cassette Unlocked”.

Alarm Help Screens

Additional information may be available on the pump display when certain alarms occur. With these alarms, help screens describe what you can do to try to solve the problem that is causing the alarm.

1. When an alarm occurs, select **Silence** to quiet the alarm.

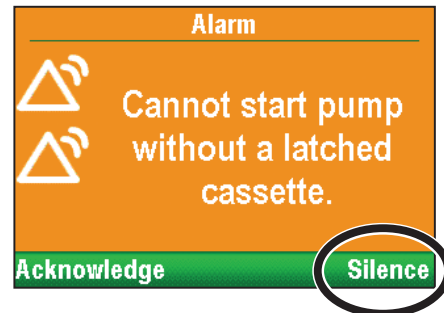

2. If help screens are available for the alarm, "**Help**" appears above the right soft key. To view the help screens, select **Help**.

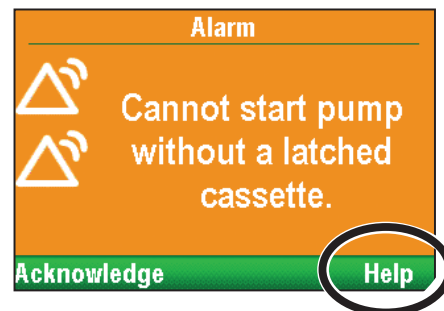

3. Follow the instructions provided on the help screen. To page through all available help screens, select **Next** to advance to the next page, if available.

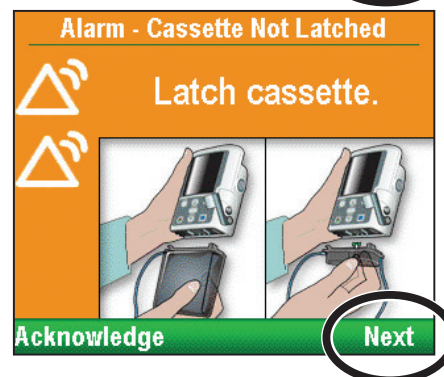

4. Select **Acknowledge** at any time to exit Help. "**Retry Help**" appears at the end of the available help screens to let you view them again.

If you cannot resolve the alarm by following the help screens, contact your health care provider.



CADD™

Smiths Medical ASD, Inc.
St. Paul, MN 55112 USA
1 800.258.5361 (USA)
1 214.618.0218
www.smiths-medical.com

CE
0473

CADD-Solis, CADD, and the CADD and Smiths Medical design marks are trademarks of Smiths Medical. The symbol ® indicates the trademark is registered in the U.S. Patent and Trademark Office and certain other countries. All other names and marks mentioned are trade names, trademarks, or service marks of their respective owners.

© 2010, 2011 Smiths Medical. All rights reserved.

2011-08
40-5909-51C

smiths medical